



## Description

The long connector for 1-phase track systems comes in white and black: the white option provides clean, efficient connectivity to enhance modern lighting setups, while the black option ensures stylish connectivity ideal for contemporary lighting installations. Protection class: I, Protection rating: IP20, Voltage: 250VAC. Article number: V115120N0W, V115120N0B.

## 1 Phase Feedin MS

Size	172x35x18mm
Protective class	1
Material	Polycarbonate
IP Rating	IP20
Voltage	250V~
Current	max.16A
Frequency	50/60Hz
Weight(kg)	0.08

## Technical drawing

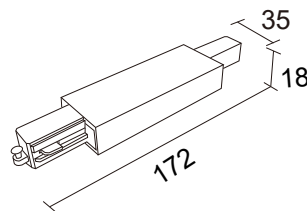

## Installation diagram

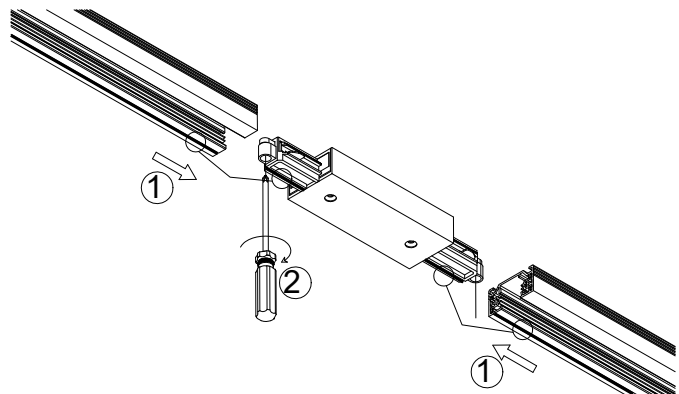

Color	Art.No
○	V115120N0W
●	V115120N0B

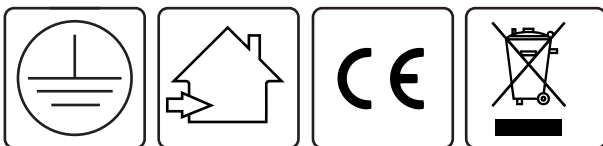

### Disclaimer

All technical data as well as weight and dimension specifications are based on standard values and have been carefully prepared. We reserve the right to make technical changes at any time to reflect progress. Product images are for illustrative purposes and may differ from the original. Errors excepted.

As of: 20/06/2025. Orders are subject to our General Terms and Conditions of Sale, available at <https://www.vysnlighting.com/de/pages/agb>