



Description

The line connector for the 1-phase Wing system ensures smooth and secure connections, enabling efficient power transfer and seamless lighting designs.

Protection class: I, Protection rating: IP20, Voltage: 250VAC.

Article number: V113922N0B.

1 Phase Track Wing Lineconnector

Size	54x19x17mm
Protective class	1
Material	Polycarbonate
IP Rating	IP20
Voltage	250V~
Current	max.16A
Frequency	50/60Hz
Weight(kg)	0.016

Technical drawing

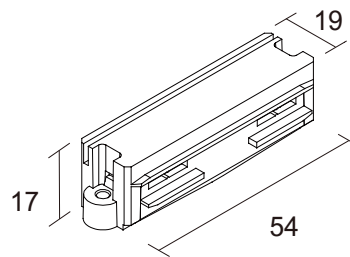

Installation diagram

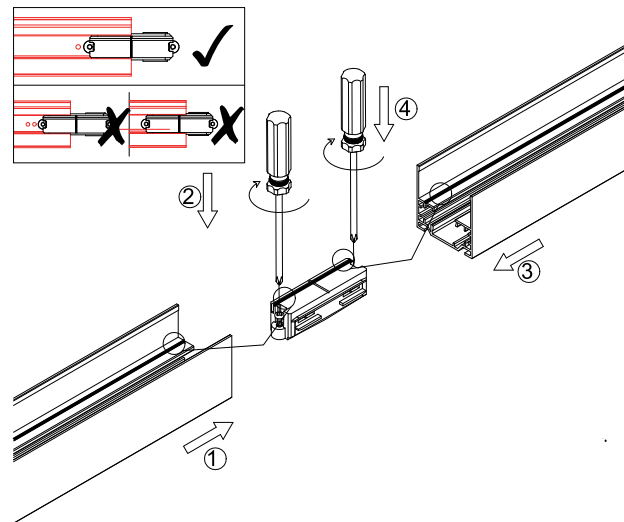

Color	Art.No
●	V113922N0B

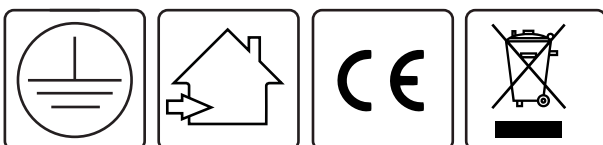

Disclaimer
All technical data as well as weight and dimension specifications are based on standard values and have been carefully prepared. We reserve the right to make technical changes at any time to reflect progress. Product images are for illustrative purposes and may differ from the original. Errors excepted.
As of: 31/07/2025. Orders are subject to our General Terms and Conditions of Sale, available at <https://www.vysnlighting.com/de/pages/agb>